

G



VISUAL

PARÀMETRES DE REFERÈNCIA:

POSSIBILITATS D'ABAST

G.1 -- ABAST VISUAL A L'EXTERIOR

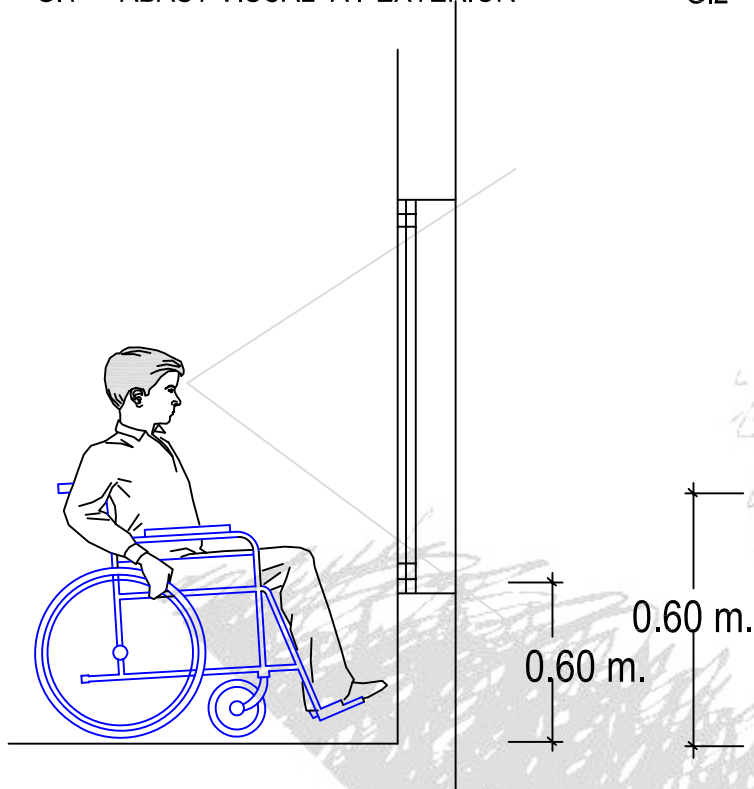

G.2 -- ABAST VISUAL SOBRE UN MIRALL

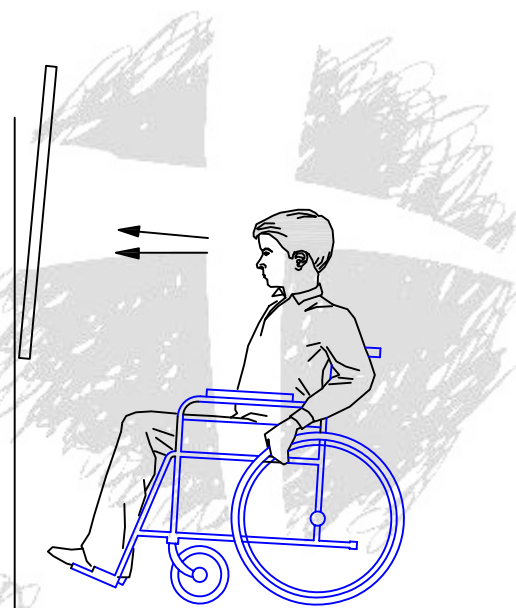

G.3 -- ABAST VISUAL HORIZONTAL

